



Integrated Sensing Platform (ISP)



ITT

Integrated Sensing Platform (ISP) Overview

Intelligent Design Drives Reliable, High Performing Valve Sensing

The Integrated Sensing Platform (ISP) is the next generation of linear position sensing developed specifically for the toughest applications in the Biopharm and sanitary industries.

This ultra-compact sensing module is the result of Engineered Valves partnering with a recognized leader in valve communications and control. Combining Engineered Valves knowledge of valve design with cutting edge valve position feedback and network communications, the ISP delivers industry leading sensing technology for EnviZion and Pure-Flo hygienic diaphragm valves.

With an optional internal solenoid, commissioning the ISP couldn't be easier. A simple mounting configuration, auto calibration and continuous sensing make the ISP quick and reliable to install, calibrate and operate.

Constructed of highly durable, lightweight plastic with completely potted electronics, the ISP is well suited for typical industry washdowns.



ISP mounted on EnviZion valve

Features and Benefits

ISP Features

- Ultra-compact design¹
- FM certified 3 wire, ASi, DeviceNet[®]
- Automatic calibration
- Optional diagnostics functionality
- 100% external calibration and solenoid override capabilities
- Reliable position sensing with non-contact magnetic resistance sensors
- Output/Bus Options: 2 wire, 3 wire, ASi, DeviceNet[®]
- High visibility LED lights
- Programmable open/closed LED color selections
- High strength, corrosion resistant polycarbonate and PES construction
- Potted electronics protected against moisture ingress and temporary immersion (IP67, Nema 4X rated)
- Integral solenoid valve option (Cv = 0.2)
- 1/8" NPT air connections (inlet, actuator, exhaust)
- M12 male quick connector standard
- Observation window (clear window to view actuator stroking)



Integrated Sensing Platform (ISP)

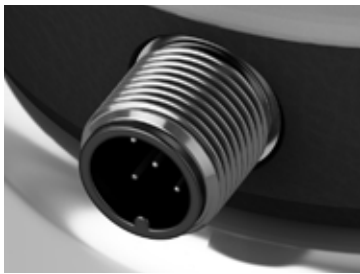

M12 Connector

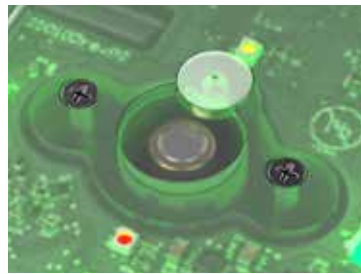

Observation window

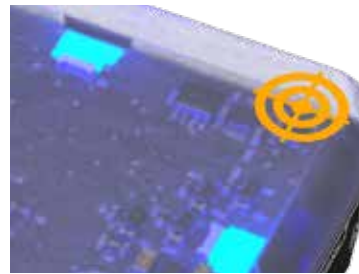

Calibration target



Dongle

ISP App Features

- iOS app for remote calibration of sensing positions
- Device Winking - determine location of device visually via blinking LED lights
- Cycle Counting - record number of open/closed cycles over date range or lifetime
- Valve data storage and retrieval for operating and maintenance history

Diagnostic Data		
Valve Position		
Stroke Time	Baseline	Last
Closed-To-Open	2.86s	2.86s
Open-To-Closed	2.12s	2.12s
Closed Break	2.69s	2.69s
Open Break	1.92s	1.92s
Cycle Count:	32	Reset Count

ISP App diagnostic data

Note: Consult factory for current list of certified countries.

¹Patent Pending



Dimensions

Ultra-Compact Design

The ISP features an ultra-compact design that allows for the utmost in installation flexibility. The ISP can be adapted to the entire range of ITT actuators from fractional (.25, .375, 0.5) through 4" valves.

The ISP design utilizes a fully potted base module. This module is adapted to the specific actuator based on type and size. The fractional (.25, .375, 0.5) through 1" valves require no mounting plate. The 1.5 – 2" valves require a 0.62" tall mounting plate. The 3" and 4" valves require a mounting plate and module with an extended dome to accommodate longer valve strokes. 0.75 and 1" ACS actuators require a mounting plate.

ISP Modular Mounting System

The ISP modular mounting system is designed to minimize overall valve installation height and to keep electronic module inventory to a minimum. The system uses two modules, a low profile version for use on the fractional (.25, .375, 0.5) through 2" valves and a tall version to accommodate the longer strokes of 3" and 4" valves.

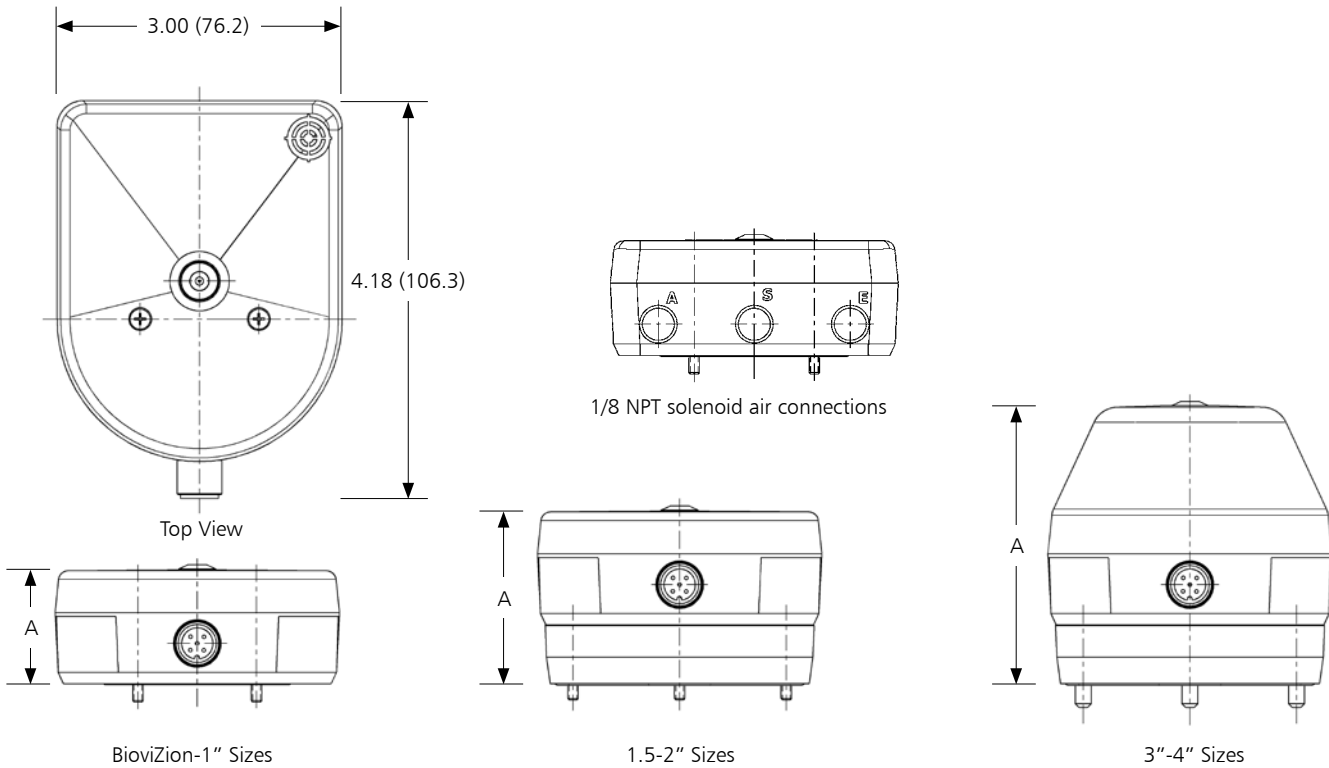

Valve Size		Overall Height (A)	
Inch	DN	Inch	mm
BioviZion – 1"¹	DN6-DN25	1.20	30.5
1.5 – 2"	DN40-DN50	1.95	50
3 – 4"	DN80-DN100	2.93	74.4

¹0.75 & 1" ACS require a mounting plate

Note: See Installation, Operation and Maintenance manual for mounting kit details and part numbers.

Minimum Valve Stroke (all sizes)	Inch	mm
ISP Unit w/o Mounting Plate	0.10	2.5
ISP Unit with Mounting plate	0.20	5.0

Sensing and Control

Reliable Position Sensing

ISP position sensing employs cutting edge magnetoresistive technology that maximizes position feedback accuracy and reliability. This technology draws little power and is particularly resistant to the effects of temperature change. The use of this proven technology results in the ISP being best in class in accuracy, power consumption and overall size.

Features and benefits:

- Non-contact sensors provide extended service life.
- Highly accurate over wide temperature ranges
- Open and close position are automatically calibrated
- Deadband is automatically adjusted based on valve stroke length
- Electronics are completely potted to protect against moisture and vibration
- Calibration is initiated with a magnetic dongle; no entry into the module is required

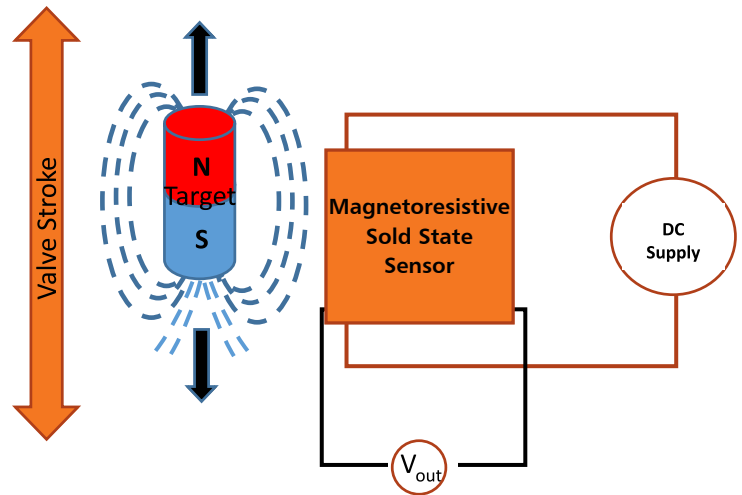

Integrated Pneumatic Control

The ISP features optional integrated control capability within the same footprint as the base module. There is no requirement for a bulky external solenoid that takes up precious space in the process system. An optimized solenoid with a Cv of 0.2 GPM draws 0.9W of power to operate valves quickly and efficiently. This allows valve response time to be minimized while a full complement of field devices can be powered by the network. Modules supplied with an internal solenoid can be operated as standard by the magnetic dongle or optionally with the ISP app.



Approximate Opening Times w/ Integral ISP (SV) Solenoid

Valve Sizes	Size Range	Typical Time (Seconds)
	0.25 – 2"	<2
	2.5 – 4"	5 – 10

Note: opening times depend on a variety of factors including actuator configuration, air line piping and process line conditions. Your results may vary.

ISP Outputs & Network Options

Discrete	Network
2 Wire	Asi 3.0
3 Wire	DeviceNet

Sensor Specifications for ISP with 2-Wire Discrete

Specifications	Notes
Configuration	(2) Two wire solid state switches (sensor powered by "closed" switch) (0 or 1) Integral Solenoid connector with LED

Environmental Specifications	Maximum
Ingress Protection Degree	IP67
Location	Indoor

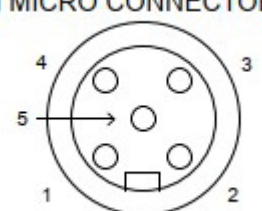
Sensor Specifications	Notes	Minimum	Typical	Maximum	Units
Operation	Normally Open (solid state)				
Supply Voltage range		8	24	30	V
Operating Current	On state current	2.0		100	mA
	Leakage current standard Stroke	260	270	340	μ A
	Leakage current Long Stroke (LS)	370	380	420	μ A
"Make" deadband	From Closed Set Point		25		% Full Stroke
	From Open Set Point		40		
Connector	5 Pin M12 Male A-coded	<p>5-PIN MICRO CONNECTOR (M12)</p>  <p>MALE (PINS)</p>			
	Pin 1: Open/Closed Common Pin 2: Closed NO Pin 3: Open NO Pin 4: Solenoid Power 1 Pin 5: Solenoid Power 2				

Discrete Inputs	Notes	Maximum	Units
"No Load" Protection	Yes, Protected from direct application of 30 VDC all pins	Continuous	Minutes

Sensor Specifications for ISP with 3-Wire Discrete

Specifications	Notes
Configuration	(2) Discrete N.O. Push-Pull Input. Self-learning outputs ¹ for NPN/PNP/Sinking/Sourcing PLC input cards. (0 or 1) Integral Solenoid(s). Self-learning control input ¹ for NPN/PNP/Sinking/Sourcing PLC output cards.

Environmental Specifications	Maximum
Ingress Protection Degree	IP67
Location	Indoor

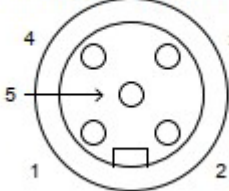
Sensor Specifications	Notes	Minimum	Typical	Maximum	Units
Operation	Normally Open (solid state)				
Supply Voltage range		18	24	30	V
Operating Current	Supply = 24V, 1 LED Color ON, Solenoid OFF Supply = 24V, 1 LED Color ON, Solenoid ON		20 65		mA
Operating Supply Power	Supply = 18-30V, 1 LED Color ON, Solenoid OFF Supply = 18-30V, 1 LED Color ON, Solenoid ON			0.6 1.8	W
"Make" deadband	From Closed Set Point From Open Set Point		25 40		% Full Stroke
Connector	5 Pin M12 Male A-coded	<p>5-PIN MICRO CONNECTOR (M12)</p>  <p>MALE (PINS)</p>			
	Pin 1: 24V+ (L+) Pin 2: Open Signal (DI) Pin 3: 24V- (L-) Pin 4: Closed Signal (DI) Pin 5: Solenoid Signal (DO)				

Discrete Inputs	Notes	Maximum	Units
"No Load" Protection	Yes, Protected from direct application of 30 VDC all pins	Continuous	Minutes
PLC Card Compatibility	Self-learning outputs ¹ (inputs to PLC) configure themselves to the card used, whether it be PNP/NPN/Sinking/Sourcing, as long as the Minimum On state current rating is met.		

¹Patent Pending

Sensor Specifications for ISP with AS-Interface

Specifications	Notes
Communication Protocol	AS-Interface v3.0
Configuration	(2) Discrete Inputs, 62 Devices per network (0 or 1) Integral Solenoid(s)

Environmental Specifications	Maximum
Ingress Protection Degree	IP67
Location	Indoor

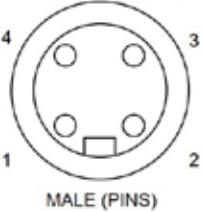
Sensor Specifications	Notes	Minimum	Typical	Maximum	Units
Supply Voltage Range	Use ASi Power Supply	26.5	30.55	31.6	V
Operating Current	1 LED Color ON, Solenoid OFF, Over Voltage Range 1 LED Color ON, Solenoid ON, Over Voltage Range		23 65		mA
"Make" deadband	From Closed Set Point From Open Set Point		25 40		% Full Stroke
Connector	4 Pin M12 Male A-coded	<p>4-PIN MICRO CONNECTOR (M12)</p>  <p>MALE (PINS)</p>			
	Pin 1: ASi + Pin 2: not used Pin 3: ASi - Pin 4: not used				
Manual Solenoid Override	<p>On all -SV models: Local Latching Solenoid Override. On models with -SV and -BT: Temporary Solenoid Overrides via the ISP app. Overrides are automatically de-activated when disconnecting from the unit.</p>				

Sensor Specifications for ISP with DeviceNet®

Specifications	Notes
Communication Protocol	DeviceNet®
Configuration	(2) Discrete Inputs, 63 Devices per network (0 or 1) Integral Solenoid(s)

Environmental Specifications	Maximum
Ingress Protection Degree	IP67
Location	Indoor

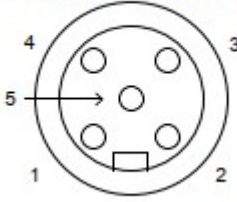
Sensor Specifications	Notes	Minimum	Typical	Maximum	Units
Supply Voltage Range	Use DeviceNet® Power Supply	11	24	25	V
Operating Current	1 LED Color ON, Solenoid OFF, Over Voltage Range 1 LED Color ON, Solenoid ON, Over Voltage Range		41 82		mA
"Make" deadband	From Closed Set Point From Open Set Point		25 40		% Full Stroke
Connector	5 Pin M12 Male A-coded	<p>5-PIN MICRO CONNECTOR (M12)</p>  <p>MALE (PINS)</p>			
	Pin 1: Shield Pin 2: V+ Pin 3: V- Pin 4: CAN H Pin 5: CAN L				
Manual Solenoid Override	On all -SV models: Local Latching Solenoid Override. On models with -SV and -BT: Temporary Solenoid Overrides via the ISP app. Overrides are automatically de-activated when disconnecting from the unit.				

Pneumatics Specifications

ISP With Pneumatics	
Manual override	Via Dongle, ISP App, PLC Output protocol (see Installation, Operation and Maintenance manual)
Configuration	Single pilot 3-way, 2-position, spring return
Flow Rating	0.2 Cv (Kv = 0.17 based on flow m ³ /hr)
Porting	1/8" NPT (Torque 5ft-lb recommended; 10ft-lb Max.)
Medium	Air or inert gas
Medium Temp. Range (TS)	-10°C to 50°C (14°F to 122°F)
Operating Pressure	25 psi to 120 psi (1.72 to 8.2 bar)
Operating Temperature	-10°C to 50°C (14°F to 122°F)
Operating Life	1,000,000 cycles
Type	Direct acting
Solenoid	
Operating Voltage	24V typical (see Installation, Operation and Maintenance manual)
Operating Temperature	-10°C to 50°C (14°F to 122°F)
Filtration Requirements	40 microns

VALVE SCHEMATIC

Single Pilot Spring Return Actuator

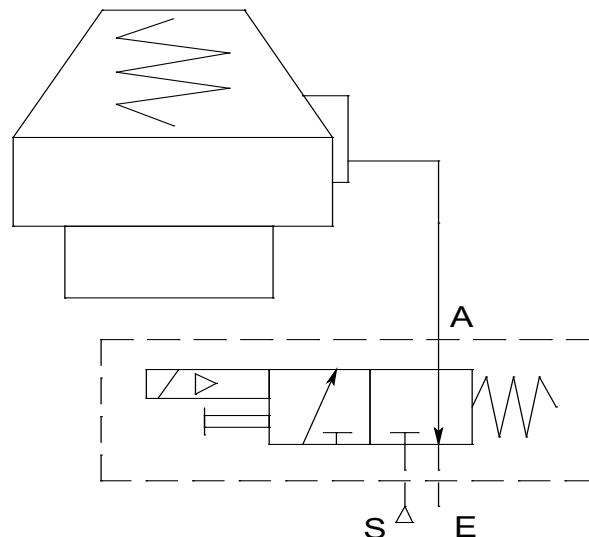

Notes:

- It is recommended to use thread tape etc. on fittings for the (S) and (A) 1/8" NPT ports.
- It is recommended that the exhaust port E be fitted with low restriction mufflers or breather vent caps or elbows etc. to prevent ingestion of water and debris into the pneumatic valve.

Calibration

Automatic Calibration

The intelligent sensing system offers precise feedback. Set up is accomplished in under one minute. Calibration can be accomplished with the dongle or via the ISP app.

Dongle Calibration

The ISP uses a dual action set-up to avoid unintended calibration.



Dongle

- A magnetic dongle is required to access control and calibration features
- LED feedback indicates calibration and solenoid over ride conditions
- ISP programming automatically sets open and closed positions

Calibration with ISP App Option

Remote calibration of valves is quick and easy with the ISP app option. An ISP with Bluetooth connectivity can be accessed from up to 33 feet (10 meters) away. Calibration and solenoid operation can be controlled through the app.



ISP app

Note: Consult factory for current list of certified countries.

ISP App Features and Benefits

- Safely control hard to reach valves without putting mechanics at risk
- Access factory preset tags and serial numbers remotely
- Electronically enter and store key valve tag numbers and maintenance logs
- Reduce network commissioning by accessing the network address and baud rate to make changes
- Reduce overall maintenance time by monitoring valve and diaphragm cycle count, cycle times and maintenance logs.
- Retrieve connected installation manuals

Diagnostics

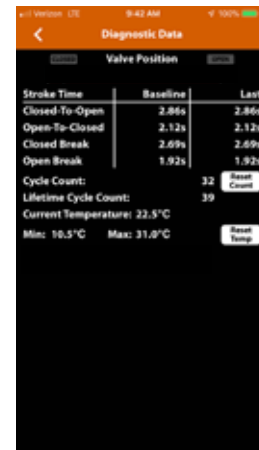

- Customize tags
- Change addresses
- Force solenoids (on/off)
- Wink the ISP module
- Initiate calibration

- Store and view additional customized information
- Connect to installation manuals
- Link to website

- View real time valve position
- View lifetime cycles
- View resettable cycle count
- Monitor ISP temperature
- Record error status

Interfacing Devices:

iPhone Version 4s and above, iPad Version 3.0 and above, iPad mini all versions. Operating System iOS 9 or above.

Note: Consult factory for current list of certified countries.

Set Up and Operation

ISP modules with diagnostics can be commissioned by conventional AS-Interface or DeviceNet programming or with conventional power source and the ISP app on standard iOS devices. Diagnostic features include:

- All powered and in range ISP units will be identified.
- A specific ISP can be remotely identified with the Wink feature, automatically calibrated, and solenoid (if equipped) can be toggled on and off.
- Once connected switch settings/status, solenoid status and operation, and diagnostic information can be accessed and open data fields can be modified.
- Remote calibration, solenoid override and addressing from the ISP app are locked when network communication is functioning.
- Allows quick commissioning as electronic tags, model numbers, serial numbers and diagnostic data can be coordinated with standard CSV/Excel files.
- Overall maintenance safety and speed of commissioning is greatly improved by keeping personnel on the ground.
- Access to IOMs and website



Certifications

US Standards	Canadian Standards	Classifications
FM Class 3600:2022	CSA C22.2 No. 213:2017	Nonincendive electrical apparatus for use in Class I, II, III, Division 2 Groups A, B, C, D, F and G;
FM Class 3611:2021	CAN/CSA-C22.2 No. 60529:2016	
FM Class 3810:2021	CSA C22.2 No. 94.1:2015	
ANSI/UL-121201:2017	CSA C22.2 No.94.2:2020	
ANSI/ISA-61010-:2012	CAN/CSA C22.2 No. 61010-1:2017	
ANSI/IEC 60529:2004		Temperature Class is T6 Tamb = -10°C to +50°C; and Class I, Zone 2, IIC T6 Tamb = -10°C to +50°C; Hazardous (Classified) indoor Locations; Type 6; IP65, IP67

ISP FM Certified Label (3W) example

WARNING – See manual for additional cautions and warnings.
AVERTISSEMENT – Veuillez-vous référer au manuel pour les avertissements et mises en garde complémentaires.

FM20US0160X, FM20CA0083X
NI: CI I,II,III, Div 2, Gp A,B,C,D,F,G T6; CI I, Zone 2, IIC, T6
Enclosure Type: 6, IP65/IP67; **Temp:** Ta = -10°C to +50°C

Model	
Serial	Date

449937

by Valmet, Fergus Falls, MN 56537, U.S.A.

CERTIFICATE OF CONFORMITY

1. HAZARDOUS (CLASSIFIED) LOCATION ELECTRICAL EQUIPMENT PER US REQUIREMENTS
2. Certificate No: **FM20US0160X**
3. Equipment: **Valve Position Monitor**
(Type Reference and Name) **ITT ISP Series Valve Position Monitor**
4. Name of Listing Company: **Valmet Flow Control Inc. (MN)**
5. Address of Listing Company: **26271 US Hwy 59**
Fergus Falls MN
56537
United States
6. The examination and test results are recorded in confidential report number:
PR457726 dated 5th April 2021
7. FM Approvals LLC, certifies that the equipment described has been found to comply with the following Approval standards and other documents:
FM Class 3600:2022, FM Class 3611:2021, FM Class 3810:2021, ANSI/UL-121201:2017, ANSI/ISA-61010-1:2012, UL 50:2015, UL50E:2020, ANSI/IEC 60529:2004
8. If the sign 'X' is placed after the certificate number, it indicates that the equipment is subject to specific conditions of use specified in the schedule to this certificate.
9. This certificate relates to the design, examination and testing of the products specified herein. The FM Approvals surveillance audit program has further determined that the manufacturing processes and quality control procedures in place are satisfactory to manufacture the product as examined, tested and Approved.

Certificate issued by:

J.E. Marquedant
VP, Manager - Electrical Systems

6 February 2023
Date

To verify the availability of the Approved product, please refer to www.approvalguide.com

THIS CERTIFICATE MAY ONLY BE REPRODUCED IN ITS ENTIRETY AND WITHOUT CHANGE

FM Approvals LLC, 1151 Boston-Providence Turnpike, Norwood, MA 02062 USA
T: +1 (1) 781 762 4300 F: +1 (1) 781 762 9375 E-mail: information@fmapprovals.com www.fmapprovals.com

F 347 (Mar 16) Page 1 of 3

CERTIFICATE OF CONFORMITY

1. HAZARDOUS LOCATION ELECTRICAL EQUIPMENT PER CANADIAN REQUIREMENTS
2. Certificate No: **FM20CA0083X**
3. Equipment: **Valve Position Monitor**
(Type Reference and Name) **ITT ISP Series Valve Position Monitor**
4. Name of Listing Company: **Valmet Flow Control Inc. (MN)**
5. Address of Listing Company: **26271 US Hwy 59**
Fergus Falls MN
56537
United States
6. The examination and test results are recorded in confidential report number:
PR457726 dated 5th April 2021
7. FM Approvals LLC, certifies that the equipment described has been found to comply with the following Approval standards and other documents:
CSA C22.2 No. 213:2017, CAN/CSA-C22.2 No. 60529:2016, CSA C22.2 No. 94.1:2015, CSA C22.2 No.94.2:2020, CAN/CSA C22.2 No. 61010-1:2017
8. If the sign 'X' is placed after the certificate number, it indicates that the equipment is subject to specific conditions of use specified in the schedule to this certificate.
9. This certificate relates to the design, examination and testing of the products specified herein. The FM Approvals surveillance audit program has further determined that the manufacturing processes and quality control procedures in place are satisfactory to manufacture the product as examined, tested and Approved.
10. Equipment Ratings:
Nonincendive electrical apparatus for use in Class I, II, III, Division 2, Groups A, B, C, D, F and G; Temperature Class is T6, Tamb = -10°C to +50°C; and Zone 2, IIC T6 Tamb = -10°C to +50°C; Hazardous indoor Locations; Type 6; IP65, IP67.

Certificate issued by:

J.E. Marquedant
VP, Manager - Electrical Systems

6 February 2023
Date

To verify the availability of the Approved product, please refer to www.approvalguide.com

THIS CERTIFICATE MAY ONLY BE REPRODUCED IN ITS ENTIRETY AND WITHOUT CHANGE

FM Approvals LLC, 1151 Boston-Providence Turnpike, Norwood, MA 02062 USA
T: +1 (1) 781 762 4300 F: +1 (1) 781 762 9375 E-mail: information@fmapprovals.com www.fmapprovals.com

F 348 (Mar 16) Page 1 of 3

EnviZion Valve

ISP Augments EnviZion Premium Valve Performance

The Biopharm industry relies on hygienic diaphragm valves for demanding process applications due to their unique balance of clean-ability, drain-ability and pressure/temperature capability. With the introduction of the EnviZion valve, ITT has set a new standard for the performance of the most common type of valve used in the industry. The EnviZion valve specifically helps customers install, operate, and maintain their valves more efficiently. This unique design provides a significant reduction in total cost of ownership while supporting the industries' goals to increase productivity, improve reliability and assure clean-ability.

Further enhancing EnviZion valve performance, the Integrated Sensing Platform (ISP) delivers unparalleled position sensing for the most critical, automated valves. With internal solenoid, auto calibration, and a wide array of output/bus options, combining the EnviZion valve with the ISP yields the most advanced valve technology in the industry today. With advantages in installation, calibration, cleanability, operation and maintenance, no other automated valve assembly matches the EnviZion valve and ISP sensing module. Specify the EnviZion valve and ISP sensing module. Specify the EnviZion valve and ISP together to bring this high performing technology to your operations and experience the benefits.



**TOOL-LESS
ASSEMBLY**



**INTELLIGENT
AUTOMATION**



**CONTAMINATION
FREE**



**SEALING SYSTEM
3RD PARTY
CERTIFIED**



**LEAK FREE
SEAL INTEGRITY**



FASTENER FREE



**ZERO
RETORQUES**

How to Order

Model codes are shown below. Here are some examples of how model numbers are constructed:

- 3 Wire, no solenoid, 0.25"-2" cover size, no diagnostics: ISP-3W-HZ
- 3 wire, with solenoid, 0.25"-2" cover size, with diagnostics: ISP-3W-SV-BL-HZ
- ASi, no solenoid, 2.5"-4" cover size, no diagnostics: ISP-AI-LS-HZ
- ASi, with solenoid, 0.25"-2" cover size, with diagnostics and control: ISP-AI-SV-BT-HZ

Product		Output		Solenoid		Cover Size		Diagnostics		Application		Custom Configuration	
Code	Option	Code	Option	Code	Option	Code	Option	Code	Option	Code	Option	Code	Option
ISP	ASi	AI	None	-	0.25"-2"	-	None	-	Hazardous Location	HZ	None	-	-
	2 Wire	2W	Included	SV	2.5"-4"	LS	*With Diagnostics	BL	-	-	Custom Configuration	PXXXX	
	3 Wire	3W					*With Diagnostics and Control	BT	-	-			
	DeviceNet	DN							-	-			

*Note: Consult factory for current list of certified countries.

As of 4/21 ISP 3W,AI, DN models are FM certified HZ application rated as standard.
2W models are General Purpose.



ITT Engineered Valves
33 Centerville Road
Lancaster, PA 17603, USA
Tel: +1 (717) 509-2200

Cam-Line, Cam-Tite, Dia-Flo,
EnviZion, Pure-Flo, Skotch

ITT Engineered Valves
1110 Bankhead Avenue
Amory, MS 38821, USA
Tel: +1 (662) 256-7185

Fabri-Valve

ITT Bornemann GmbH
31683 Obernkirchen
Germany
Tel: +49 5724 390-0

EnviZion, Pure-Flo

